

OPERATING INSTRUCTIONS

HIRLINGER
STROHHEXE

| | | |
|---------------|------------------------------|------------------------|
| SHE 5 | Motor 4 KW/ 5,5 PS | Rated revs 1000 |
| SHE 10 | Motor 7,5 KW/ 10 PS | Rated revs 1500 |
| SHE 12 | Motor 9,2 KW/12,5 PS | Rated revs 1500 |
| SHE 15 | Motor 11 KW/ 15 PS | Rated revs 1500 |
| SHE 20 | Motor 14,7 KW/ 20 PS | Rated revs 1500 |
| SHZ 15 | Gears for tractor PTO | |



Table of Contents

| | |
|--|-------|
| 1 Notes on the operation of the HIRLINGER-Strohhexe | 3 |
| 2 HIRLINGER-Strohhexe – the straw shredder for ideal bedding and litter | 3 |
| 3 First start-up | 4 |
| 4 Safety measures | 5 |
| 5 Straw shredding – operating instructions | 6 |
| 6 Formation of dust, and preventive measures | 7 |
| 7 Installation and operation of the water spray nozzle | 7 |
| 8 Changing sieve and blades made easy | 8 |
| Changing the sieve | 8 |
| Changing the angled blades | 8 |
| Turning and exchanging the rasps | 8 |
| Turning and exchanging the blades | 8 |
| 9 What to do when | 9 |
| 10 List of replacement parts, SHE 5 - SHE 20 | 10-11 |
| 11 List of replacement parts, SHZ 15 | 12-13 |
| 12 Machine data and dimensions | 14 |
| 13 Important notice on warranty | 14 |
| EC Declaration of Conformity | 15 |

1 Notes on the operation of the HIRLINGER-Strohhexe

Dear Customer, You have made a wise decision.

The HIRLINGER-Strohhexe will serve you well for many years if you take note of a few points that we have put together for you in these Operating Instructions. To ensure that the machine functions correctly and efficiently, you should read our instructions carefully and be sure to act on our advice.



Use the HIRLINGER-Strohhexe only for the purpose for which it is intended! That is, use it only for absolutely dry hay and straw! Straw that is moist, or has been stored outdoors, does not break, and cannot be shredded! So make sure that you remove wet material before starting work.



Straw from hemp or flax cannot be processed in the Strohhexe! Hemp and flax straw fibres do not break. They would form "plaits," which would lead to overloading of the motor.



Do not process other materials, such as shavings or bark! The machine is not suitable for these. Nor is the machine suitable for shredding garden waste.

Improper use voids any claim under warranty.

In case of damage, use only original replacement parts! We will be pleased to help you to repair damage at any time.

Should you encounter difficulties when working with the straw shredder that are not dealt with in the Operating Instructions, or if anything is unclear about operation or possible repair, we will give you help and advice.

Fidel Hirlinger Landtechnik
Proprietor Achim Hirlinger
Unter den Linden 17
D-72393 Burladingen-Melchingen
Germany
Phone + 49 71 26 10 20
Fax + 49 71 26 12 47
info@hirlingerland.de

2 HIRLINGER-Strohhexe – the straw shredder for ideal bedding and litter

The HIRLINGER-Strohhexe is used to chop long straw. The stems of the straw are shortened and split. The short straw is then blown out by means of ejector blades. The result is the ideal litter for all kinds of animals and poultry.

And here's how it works: The long straw, whether pressed or loose, is fed into the HIRLINGER-Strohhexe through the hopper. Toothed rasps distribute the straw to the periphery, and feed it evenly, slightly shortened, into the shredder.

This consists of 24 rotating, moving blades and a shredding basket (insets with holes of different diameters). In the shredding basket, the straw is shredded until it is short and small enough to emerge from the perforated sieve. Once outside the sieve, it is caught by the ejector blades and blown away. Either sheet-metal or plastic pipes can be used to convey it from there.



Apart from straw, hay and alfalfa may also be processed. This is very popular as a fodder additive or for mixing fodder.



Straw that is moist and tough can not be processed. Fibres that do not break clog the holes in the sieve, jam the throughput and overload the machine. Depending on the force, this can lead to destruction of the drive and the sieve.

The machine has been deliberately designed with low blowing power. This has the great advantage of keeping the cloud of dust that emerges comparatively small. However, it also means that the machine must be fed from above, and the blowing distance should not be more than 10 to 12 metres.

3 First start-up

HIRLINGER-Strohhexe SHE 5 Electric drive 4 KW/1000 rpm

The machine stands vertically, or optionally at an angle on the supporting wheel provided.

1. Apply the brake on the supporting wheel.
2. Remove any foreign bodies from the interior.
3. Fit and tighten the pipe.
4. Plug the supplied cable into the machine.
5. Plug into the electric socket. The motor switch has two positions: 0 and I. There is a motor protection switch integrated (overload protection).
6. Press button I; the machine idles. The direction of rotation must be to the left as you look into the machine, i.e. anti-clockwise.
7. On finishing work, switch off the machine and pull out the plug.

HIRLINGER-Strohhexe SHE 10, SHE 12, SHE 15, SHE 20 Electric drive 7,5 / 9,2 / 11 und 14,7 KW, je 1500 n

The machine stands vertically, or optionally at an angle on the supporting wheel provided.

1. Apply the brake on the supporting wheel.
2. Remove any foreign bodies from the interior.
3. Fit and tighten the pipe.
4. Insert 32 amp plug in electric socket (fuse at least 20-25 amps, slow-blow). The motor is protected from overload, overheating and phase-failure. There are 2 switches installed: the motor protection switch with 0-voltage release, and the star delta starter switch. The motor protection switch has 2 positions: 0 and I. It locks in only when 220 V are present on all 3 phases of the power feeder line.
5. Set the motor protection switch to I.
6. Then turn the star delta starter switch from 0 to stage Y. In this position, wait for approx. 10 seconds, until the revs stop increasing. Then switch smartly to position Δ!
Do not forget to do this, or the motor will not run properly, and will be heavily overloaded!!!
The machine is now idling. The direction of rotation must be to the left when you look into the hopper, i.e. anti-clockwise.
7. On finishing work, turn the star delta starter switch back to 0, pull out the plug, and coil the cable on the holder provided.



HIRLINGER-Strohhexe SHZ 15 drive via tractor PTO 540 rpm, 25 KW or higher

The machine stands upright behind the tractor.

1. Couple to the upper and lower links.
2. Mount the drive shaft, snap the pins in place, attach the safety chains.



Make absolutely certain that the drive shaft is the correct length. If it is too long, it may damage the gears when being lifted out. The machine should preferably be standing on the ground. However, you can work with the machine in a raised position when the lower links are locked.

3. Remove any foreign bodies from the interior.
4. Fit and tighten the pipe.
5. Switch in the PTO.

The maximum speed of rotation is 540 rpm.

Attention: Always run the machine in anti-clockwise direction!

Important: When operating on a front PTO, reversing gears may have to be used.

6. On finishing work, let the machine idle to a standstill.
Do not use the motor as a brake!



4 Safety measures

When working with the machine, observe the safety regulations of your mutual indemnity association and our notices at all times.

You are working with a machine that may constitute a source of danger. Only persons who are familiar with the work and who observe the safety regulations are permitted to operate the machine. You may stand in front of or beside the machine.



Persons must not stand in front of the outlet. There is a risk of foreign bodies being ejected from the machine!

You can never exclude the possibility of foreign bodies being present in the straw. The machine itself is not susceptible to damage through foreign bodies; however, the rotation of the grinding mechanism may throw foreign bodies out of the hopper. Metals in particular may cause sparks. Pieces of wood can also constitute a risk if they get caught in the grinding mechanism and become hot through friction!



For this reason, do not leave the shredder to run unattended. In dangerous situations, switch it off immediately! Do not put your hands into the machine while it is running! If it is jammed, switch it off and wait until it comes to a standstill.

In the case of PTO machines, ensure that the permitted rotation speed of 540 rpm is not exceeded. Ensure that the protective parts of the drive shaft are in good condition.



Before working on the machine, always wait until it has come to a standstill, and then secure it against inadvertent start-up.

When working on the machine, be aware of the danger of injury by sharp blades.



Claims under warranty are voided:

- In cases of improper use
- When maintenance or repair are carried out with non-original replacement parts
- When unauthorised alterations are made to the machine

In all the above cases, there is a danger of damage to the machine or injury to persons.

5 Straw shredding – operating instructions

Start up the machine as described in 3 “First start-up.” Hold compressed bales by the twine bindings, and let them slide slowly into the hopper from above. Keep hold of the twine. It will be cut open by the angled blades. Then pull the twine out. This process is completely safe! The straw is drawn in without pressure. Wait until 2/3 of the bale has been processed, then set the next bale on top of it, and repeat the process.



Do not push the straw down by hand or with a pitchfork – use the weight of the next bale!

Should there be foreign bodies in the straw, stop the machine immediately. When it has come to a standstill, remove the remaining straw, free it of the foreign bodies, and start up again.

When working with round bales, square bales or loose straw, feed the straw loose into the hopper with a pitchfork. Take small heaps. Avoid tamping the straw down in the hopper. This is the surest way to increase the performance. Because the machine has a low-power blower, the suction effect is also low. However, this also means that less dust is produced.

In the case of square-baled straw, it is best to halve the cakes with a pitchfork, and insert them in this form. This is quicker than doubling up the cakes. Take great care to ensure that no twine or netting get into the machine. These could get wrapped around the blade pins, and would then be very difficult to remove. Apart from that, the twine adversely affects the performance. Should remnants of twine get into the litter, there is a risk of the animals eating the twine along with it.



Should you hear unusual noises, such as "rattling", "whining" or "squeaking" during work, stop the machine immediately, identify the cause, and remedy it. Rubbing parts and foreign bodies could cause flying sparks and set fire to the straw. Danger to house and outbuildings!

If you notice during shredding that the machine is labouring, open the air inlet to the blower from below, using the sliding cover (see the illustration on the right). To do this, push the operating lever towards the wheels. It is infinitely adjustable, and usually a movement of 5 -10 cm is enough to reduce the loading. After this, the machine sucks in most of the air from below, the speed of throughput is reduced,

and the machine works more easily. This situation arises only when there are no perforated sieves installed and the straw is tough rather than dry (even some spraying media may have this effect. See also green straw.) If this kind of straw has to be processed, it usually helps to install a coarser perforated sieve.



In the case of machines with electric motors, a motor protection switch to prevent overloading, and a motor circuit-breaker to prevent overheating are installed as standard.

This motor circuit-breaker cuts off when overloaded, and the machine comes to a standstill. Only then remove the remaining straw. Set the star delta starter switch to 0. Set the motor protection switch to I, and start up again, using the star delta starter switch. Exception: In the case of the SHE 5, the contact-breaker is also the On/Off switch.

Overloading when the machine is operating on a tractor is indicated audibly by the tractor revs dropping. The machine starts to rattle audibly. Remnants of straw squeeze through between the blades and the sieve! Stop the machine immediately!



Continuing to work would sooner or later destroy the sieves and the machine. The sieves bend outwards, the gaps between the blades and the sieves increase, and the efficiency becomes less and less. The same applies here: use larger sieve perforation! Process dry straw only.

We categorically guarantee that well-dried straw can be processed without trouble by all the machines that we offer.



6 Formation of dust, and preventive measures

It is impossible to process straw without producing dust. Our machines are therefore designed in such a way that air movement is slight, but function and performance are not impaired. However, the disadvantage of the smaller "cloud of dust" is that the machine cannot suck in straw from below. It must therefore be fed from the top.

Straw has residue of soil and dust, and sometimes mould, adhering to it. During shredding, these are blown away and swirl through the air, emerging as a cloud of dust. Wherever this must be prevented, you can work with a water spray nozzle. A holder for this accessory is fitted to all machines as standard.

During the shredding process, the spray nozzle sprays between 0.2 and 0.5 litres of water per minute into the running machine from below. This means that the shredded straw is slightly moistened. This binds the dust to the straw.

Several points are important here: The chopped straw should not be stored for longer than 4 - 6 weeks. Also, chopped straw cannot be conveyed for any great distance, because it can get gummed up in the pipelines. Longer chopped straw cannot be conveyed as far as shorter chopped straw. The pipelines get blocked much sooner. Shredding is more difficult, mainly when there is a lot of water. More powerful motors are then required.

When compressed bales are being processed, these may be moistened by pouring about ¼ litre of water over them immediately before feeding them into the machine. This binds the dust in a similar way to the water spray nozzle. Attention: Never moisten more than 1 or 2 bales beforehand, because shredding would then be impossible.

Blowing into enclosed spaces

It is possible to blow in enclosed spaces with the straw shredder. The bigger the space, the better. However, a ventilation system must be present, either a waste-air pipe or a waste-air filter. Pipe diameter approx. 450 - 500 mm, filter area approx. 1 m².

Blowing on trailers or lorries

When blowing takes place on a trailer or lorry, those should be covered with a grille that permits air to pass through. This way, the load space can be filled, the air can escape, and the material stays in the vehicle. In a completely airtight vehicle (horse-box), the air is blown back out again with particles of the material and dust. This makes for unpleasant work.

7 Installation and operation of the water spray nozzle

The water spray nozzle serves to suppress or prevent excessive production of dust when shredding straw. This is achieved by spraying a water mist on the already shredded straw inside the blower housing.

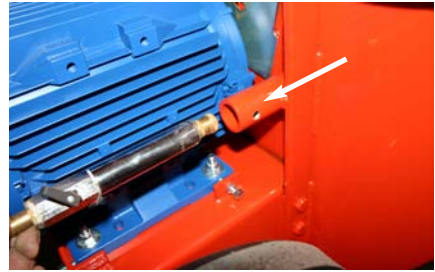

Connect a water hose to the water spray nozzle. There is a piece of tube welded onto the housing of the HIRLINGER-Strohhexe at the bottom right (see photo). This has a small opening into the interior of the blower. The water spray nozzle is inserted into this tube from below as far as it will go. It is fixed in place with an M10 screw, which is screwed into the tube provided. Only tighten the screw lightly.

Operating the shredder with the water spray nozzle

Start up the machine as described in the Operating Instructions. First lay some straw in it. Only then open the tap for the water spray nozzle slightly. Straw must now be fed continuously. Observe whether the dust production decreases. The more water, the less dust, and, of course, vice versa. Note the optimum position of the water tap. Too much water leads to blocked pipes. Finish work in the reverse sequence: first close the water tap; then process some dry straw, so that no deposits can form in the machine, and the machine dries out.



Always store the water spray nozzle in a moderately tempered room in winter. Frost would destroy the nozzle.

If you work with the water spray nozzle often, the shredding chamber must be inspected frequently for deposits of dirt, otherwise the ejector blades may rub on the edge deposit!

If the nozzle is dirty, the front part can be screwed off to clean the nozzle.

8 Changing sieve and blades made easy

Changing the sieve (No. 4)

1. With the machine standing upright, disconnect the electric plug or the PTO shaft.
2. With an SW 19 spanner, loosen the 4 nuts on the hopper. Remove the nuts and washers. Swing the hopper down on its hinge.
3. Insert a screwdriver between shredder and sieve (No. 4), and run it in a circle round the shredder. This pushes the blades back.
4. Lift the sieve out from the top.
5. Insert the other sieve. There are two locating pins in the housing of the machine. At the edge of the sieve and the hopper, respectively, there is a punched notch. When assembled, these two notches lie one over the other. Lay the sieve so that it fits on the locating pins.
6. Swing the hopper up.
7. Thread the washers and nuts, and tighten them.
8. Make a test run.



**Under no circumstances must the blades rub!!
Danger if flying sparks and fire!**

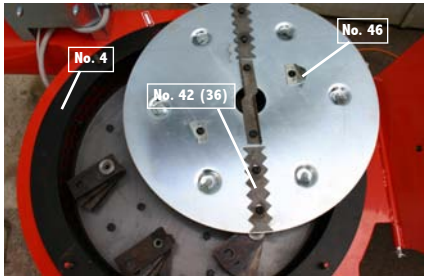

Changing the angled blades (No. 42 (36) / No. 46)

The angled blades attached to the upper disc of the shredder are intended to cut the twine of high-pressure bales. This makes it easy to work with these bales. However, as soon as the blades become blunt, the cutting no longer functions reliably. The blades should then be sharpened or replaced.

1. Swing the hopper down, as when changing the sieve
2. With an SW 6 Allen wrench, screw out both the screws that hold the blades in place
3. Grind the blades (protective goggles!), or replace them with new blades. Screw them tight.
4. Swing the hopper up, and tighten the nuts.

Turning and exchanging the rasps

There are 2 rasps fixed to the upper disc of the shredder. These distribute the fed straw evenly. If they are heavily worn, it takes longer to process the straw.

In the case of types SHE 5, SHE 10, SHE 12, SHE 15 and SHE 20, the rasps can be used on 4 sides. That means that they can be turned three more times when the first side is worn down. In the case of Type SHZ 15, the rasps are higher, and therefore distribute the material more aggressively. They take longer to wear down. However, these rasps cannot be turned, and therefore have to be replaced.

1. Swing the hopper down, as when changing the sieve
2. With an SW 6 Allen wrench, remove the 4 screws of the rasp. (The rasps on the SHZ 15 have 3 screws each!)
3. Turn the rasp over, or rotate it by 180°, and screw it tight.
4. Close the hopper and screw it tight.

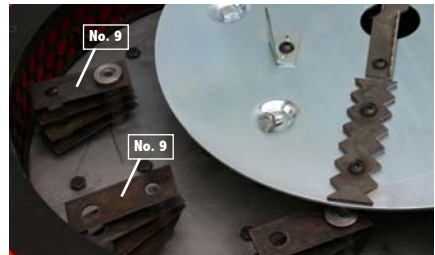

Turning and changing the blades (No. 9)

The shredder has 24 blades. Each of them is 120 x 48 x 3 mm in size, and has 2 holes. They can be used on 4 sides. The blades become blunt with use, with rounded leading edges. They must be turned sooner or later, depending on the type of straw and the size of the sieve. The blades can be used for a longer time with large holes than with small ones. In any case, the blades must be turned or exchanged as soon as the rounded edges have the radius of a small coin. The tools you will need are:

- 1 Ring spanner, SW 19 mm
- 1 Screwdriver, medium
- 1 Piece of square timber to lock the shredder

Procedure

1. Secure the machine against starting up
2. Place the machine upright
3. Swing the hopper down, as when changing the sieve
4. Fold back the blades with the screwdriver
5. Remove the sieve from the top
6. Secure the shredder against turning, using the square timber (through the outlet)
7. Unscrew the 6 M12 screws from the shredder disc
8. Lift off the upper shredder disc completely
9. Remove the blades set by set, turning each the same way. Check the pins for striations, and if necessary exchange them. Assemble blades and spacers alternately.

10. Replace the upper shredder disc, noting the marking on hub and disc (die-stamped No.). Tighten the screws lightly
11. Turn the shredder by hand, so that the blades turn outwards
12. Tighten the screws firmly. Use the square timber when doing this
13. Check that all 24 blades can be moved easily. (This is essential. If not, individual blades are not correctly assembled. Strip down again and repeat assembly steps 7-13.)
14. Insert the sieve correctly.
15. Close the hopper and screw it tight.
Carry out a test run.



The machine must not vibrate heavily; if it does, the shredder is out of balance, and the motor bearings will suffer damage.

If you are not familiar with these tasks, get in touch with your trade dealer or with us directly.

9 What to do when ...

The machine does not suck straw in, or even blows it out the top

1. Wrong direction of rotation? To the left as seen from above!
2. Pipe blocked? Empty it completely, and also empty the machine completely; the air must escape freely.
3. Air inlet open? Lever must be right at the top in the direction of the air outlet.
4. Only at the end of work? Moist straw or twine have wrapped themselves around the angled blades. Remove.
5. Pipe too long? The pipe on the SHE 5 should not be longer than 2-3 m. The pipe on the SHE 10-15 may be up to 10-12 m long. The pipe on the SHZ 15 may be up to 15 m long. In the case of plastic pipes, use only 45° bends; use 2 x 45° rather than 90° bends, because of the greater radius.



The machine develops less power than originally

1. Star delta starter switch only at **Y**, instead of at Δ ?
Switch a step farther! Motor at risk!
2. Are the rasps on the blade disc heavily worn?
Turn or replace them.
3. Backpressure in conveyor tube when blowing in enclosed spaces? Wide-area ventilation, free filter.
4. Are blades blunt? Turn or replace blades.
5. Is the sieve blocked? If necessary, open up the machine and clean the sieve. (Possible only with wet straw)

The machine does not cut the twine

1. Are the angled blades still sharp? Sharpen or replace.
2. Are the bales loosely pressed? If so, the twine slips off the blades. You can let the twine work deeper down into the machine and then remove it, or take it off beforehand.
3. Are the bales out of shape? Through transport and unloading? In this case, the twine also slips off the blades (see 2).

The motor protection switch cuts off frequently

1. Is the straw hard to shred? Use dry straw, or a coarser sieve. Open the bottom air inlet slightly. As a test, obtain 1 bale of straw from a neighbour!
2. Bad contact somewhere in the power feed cable?
Have it checked by an electrician.
3. Is the motor overheating? Has the thermal overload protection in the motor cut off? Let it cool down for about 20 minutes. Restart. Free the motor cover of straw and dust.

Motor protection switch cannot be switched on

1. Is the cable plugged in? If not, plug it in.
2. Is the star delta starter switch at 0? Switch off.
3. Are all fuses really intact? Check with voltmeter.
4. Has the thermal overload protection in the motor triggered? Let it cool down for about 20 minutes. Restart. Keep motor ventilation free.
5. Is the switch defective? Have it checked by an electrician.

Noises occur when idling

"Rattling", "whining", "scuffing"? Switch off immediately.

1. It could be that the sieve is bent and scuffing.
2. The shredder could be out of alignment with the motor because of overloading.
3. The gears could be out of alignment after lifting out because the drive shaft is too long.

Under no circumstances should you continue work until the cause is identified and the damage is repaired! Danger of flying sparks and fire!!

10 List of replacement parts, HIRLINGER-Strohhexe SHE 5 - SHE 20

| Item | Designation | Pcs./Machine | Item | Designation | Pcs./Machine |
|------|-----------------------|--------------|------|----------------------------|--------------|
| 1 | Hopper | 1 | 31 | Switch cabinet | 1 |
| 2 | Hinge pin | 1 | 32 | Screw, M8 x 16 | 4 |
| 3 | Lynch pin | 1 | 33 | Securing ring, d 70 | 1 |
| 4 | Sieve | 1 | 34 | Screw, M8 x 12 | 4 |
| 5 | Screw, M12 x 20 | 12 | 35 | Ejector blade | 6 |
| 6 | Upper disc | 1 | 36 | Screw, M10 x 20 | 18 |
| 7 | Screw, TBEI 10x16 | 4 | 37 | Lower disc | 1 |
| 8 | Pin, 18 x 70" | 6 | 38 | Nut, M 8 | 4 |
| 9 | Blade, 120 x 48 x 3 | 24 | 39 | Special disc, 10/38/6 .. | 1 |
| 10 | Spacer, h 5 | 42 | 40 | Screw, M10 x 30 | 1 |
| 11 | Spacer, h 3 | 30 | 41 | Support for switch cabinet | 1 |
| 12 | Hub | 1 | 42 | Outer rasp | 2 |
| 13 | Screw, M 12 x 35 | 6 | 43 | Inner rasp | 1 |
| 14 | Screw, M 8 x 20 | 12 | 44 | Screw, TSEI 10 x15 | 4 |
| 15 | Washer, M 8 | 12 | 45 | Guard bar | 1 |
| 16 | Support without wheel | 1 | 46 | Angled blade | 2 |
| 17 | Pulley | 1 | 47 | Screw, M10 x 45 | 4 |
| 18 | Securing nut, M 8 | 13 | 48 | | |
| 19 | Clamping screw, M 10 | 1 | 49 | Securing nut, M10 .. | 4 |
| 20 | Running wheel | 2 | 50 | Washer, M10 | 4 |
| 21 | Securing nut, M 12 | 10 | 51 | Screw, M6 x 30 | 1 |
| 22 | Type-plate sticker | 1 | 52 | | |
| 23 | Pressure spring | 1 | 53 | Securing nut, M6 | 1 |
| 24 | Lynch pin | 2 | 54 | Star delta starter switch | 1 |
| 25 | Washer, M 12 | 4 | 55 | Motor protection switch | 1 |
| 26 | Electric motor | 1 | 56 | Rotation-direction arrow | 1 |
| 27 | Rubber handle, 25/8 | 1 | 57 | Hirlinger sticker | 2 |
| 28 | Air slide | 1 | | | |
| 29 | Securing nut, M10 | 2 | | | |
| 30 | Housing, complete | 1 | | | |

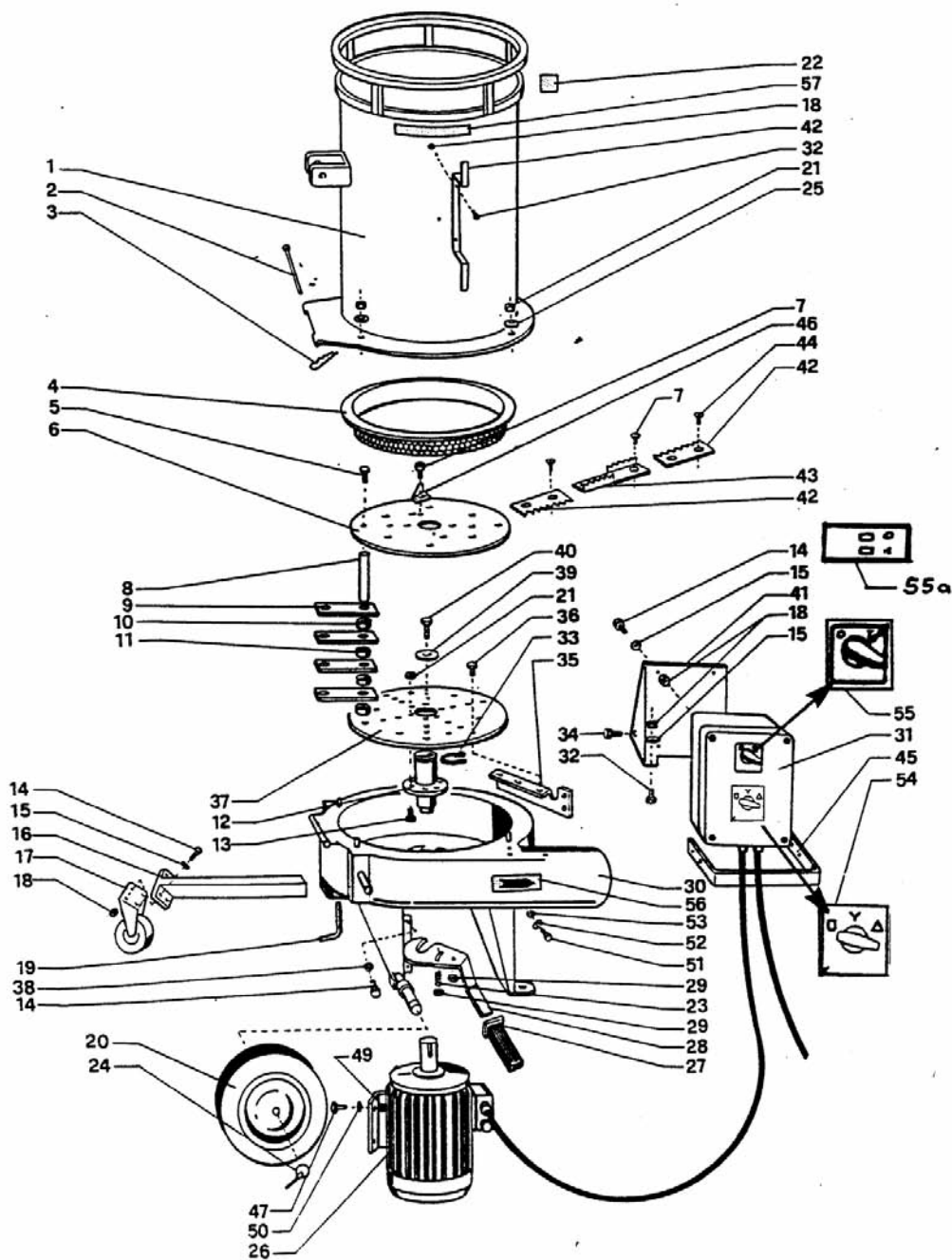

11 List of replacement parts, HIRLINGER-Strohhexe SHZ 15

| Item | Designation | Pcs./Machine | Item | Designation | Pcs./Machine |
|------|---------------------|--------------|------|--------------------------|--------------|
| 1 | Hopper | 1 | 30 | Ejector blade | 6 |
| 2 | Hinge pin | 1 | 31 | Screw, M10 x 20 | 18 |
| 3 | Lynch pin | 1 | 32 | Lower disc | 1 |
| 4 | Sieve | 1 | 33 | Nut, M8 | 4 |
| 5 | Screw, M12 x 20 | 12 | 34 | Special disc, 10/38/6 | 1 |
| 6 | Upper disc | 1 | 35 | Screw, M14 x 30 | 1 |
| 7 | Screw, TSEI 10 x 16 | 8 | 36 | Rasp | 2 |
| 8 | Pin, 18 x 70 | 6 | 37 | Angled blade | 2 |
| 9 | Blade, 120 x 48 x 3 | 24 | 38 | Chain for drive shaft | 1 |
| 10 | Spacer, h 5 | 42 | 39 | Rotation-direction arrow | 1 |
| 11 | Spacer, h 3 | 30 | 40 | Gearbox | 1 |
| 12 | Hub | 1 | 41 | Hirlinger sticker | 2 |
| 13 | Screw, M12 x 35 | 6 | 42 | Type-plate sticker | 1 |
| 14 | Running wheel | 2 | | | |
| 15 | Securing nut, M 12 | 14 | | | |
| 16 | Screw, M 8 x 20 | 4 | | | |
| 17 | Pressure spring | 1 | | | |
| 18 | Lynch pin | 2 | | | |
| 19 | Screw, M 12 x 20 | 8 | | | |
| 20 | Washer, M12 | 16 | | | |
| 21 | Gearbox bracket DX | 1 | | | |
| 22 | | | | | |
| 23 | Gearbox bracket SK | 1 | | | |
| 24 | Screw, M 12 x 30 | 4 | | | |
| 25 | Rubber handle, 25/8 | 1 | | | |
| 26 | Air slide | 1 | | | |
| 27 | Securing nut, M 10 | 2 | | | |
| 28 | Housing, complete | 1 | | | |
| 29 | Securing ring, d 70 | 1 | | | |

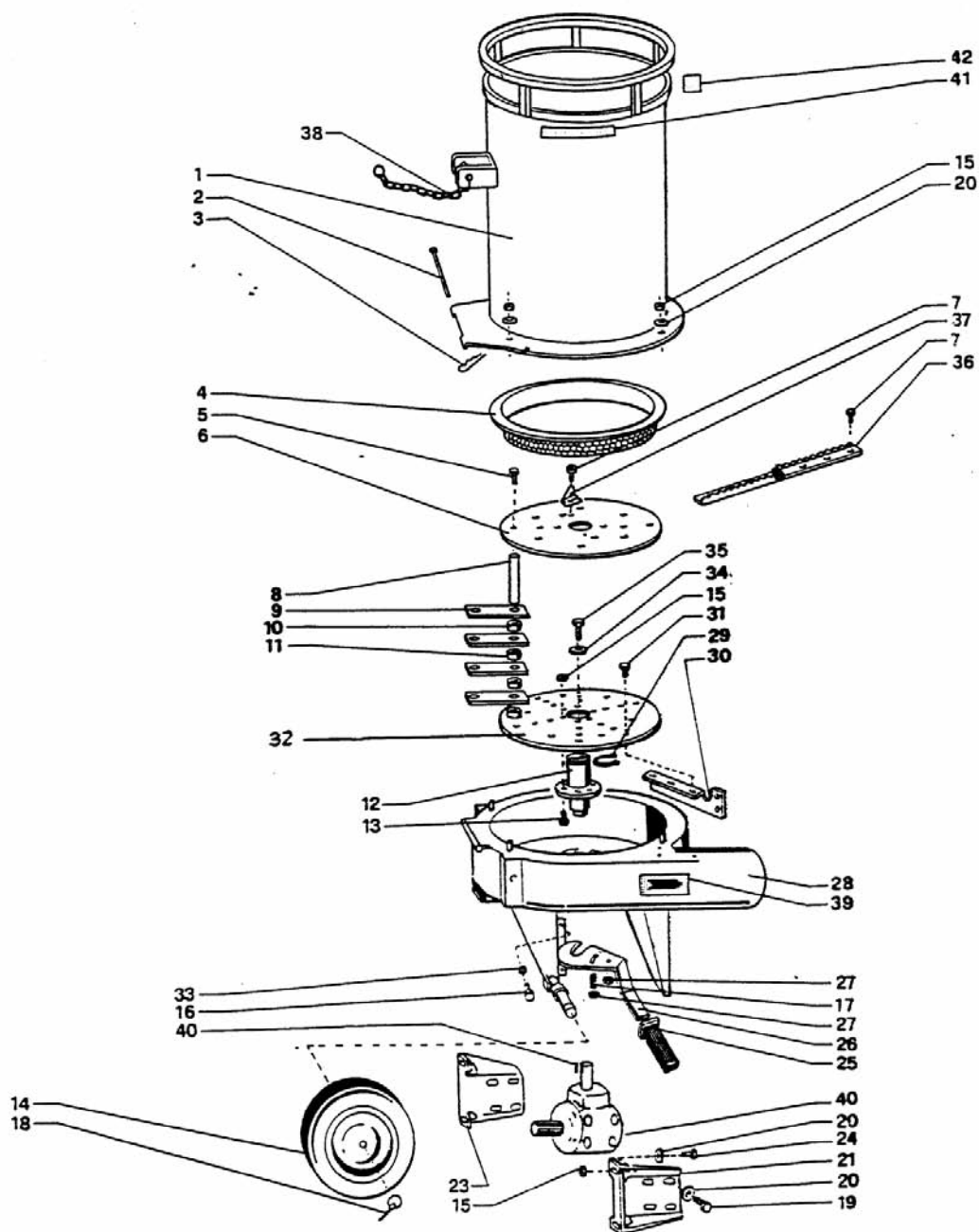

12 Machine data and dimensions

HIRLINGER-Strohhexe-Type

| | | |
|--------|-----------------------|-----------------|
| SHE 5 | Motor 4 KW/ 5,5 BHP | Rated revs 1000 |
| SHE 10 | Motor 7.5 KW/10 BHP | Rated revs 1500 |
| SHE 12 | Motor 9.2 KW/12.5 BHP | Rated revs 1500 |
| SHE 15 | Motor 11 KW/15 BHP | Rated revs 1500 |
| SHE 20 | Motor 14.7 KW/20 BHP | Rated revs 1500 |
| SHZ 15 | Gearbox for PTO | |



Pipe

Optional connections:

- 160 mm for plastic pipes
- 150 mm for grain pipes (galvanised)

Standard equipment

1 sieve from selection of

sizes: 15, 22, 26, 30, 40, 60, 70 x 100 mm.

Special equipment

- Operating-hours counter, SHE
- Water spray nozzle
- Phase inverter
- Drive shaft
- Reducing pin Cat. I : II for SHZ
- Grain pipe stub (adapter for grain pipes)



13 Important notice on warranty

In the case of faults or unusual events, get in touch with your trade dealer, or with us directly.



Alterations to the machine void any claim under warranty, and nullify the Declaration of Conformity.

In the interests of further improvements to our products, we reserve the right to make technical modifications, including alterations in dimensions and weights.

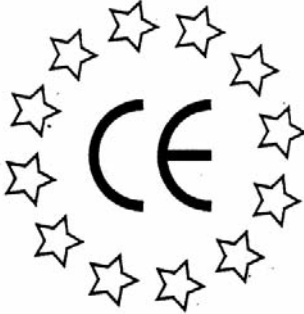

Fidel Hirlinger Landtechnik
Proprietor Achim Hirlinger
Unter den Linden 17
D-72393 Burladingen-Melchingen
Germany
Phone + 49 71 26 10 20
Fax + 49 71 26 12 47
info@hirlingerland.de
www.hirlingerland.de

Tax Number 86236/82450

EC Declaration of Conformity

The undersigned declares, on his own responsibility, that the machines

of the types **SHE 5, SHE 10, SHE 12, SHE 15, SHE 20 and SHZ 15**

with sequence numbers fulfil the essential requirements on safety and preservation of health as defined in **EC Machinery Directive 2006/42/EC**.

Burladingen-Melchingen, 2nd January, 2012

A handwritten signature in black ink, which appears to read 'Achim Hirlinger'. The signature is written in a cursive style.

Achim Hirlinger

Fidel Hirlinger Landtechnik
Proprietor Achim Hirlinger
Unter den Linden 17
D-72393 Burladingen-Melchingen
Germany
Phone + 49 71 26 10 20
Fax + 49 71 26 12 47
info@hirlingerland.de
www.hirlingerland.de

